

Our Clients



Design Core / 7709008074



Complete Protections

GUJAR INDUSTRIES

(Machine Tools Protection Equipment Division)

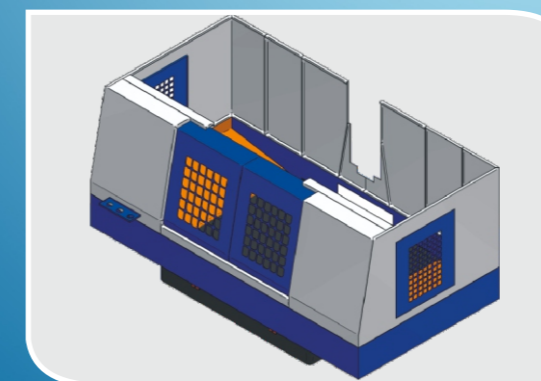
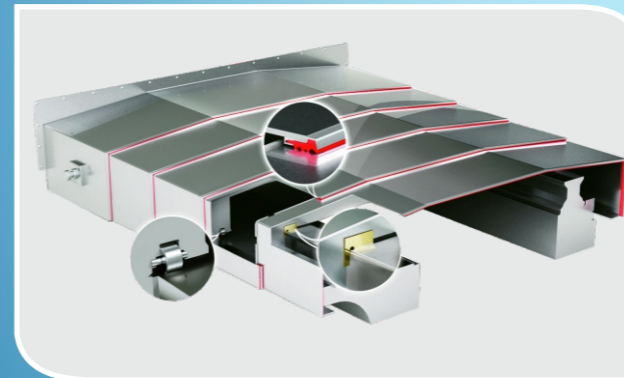
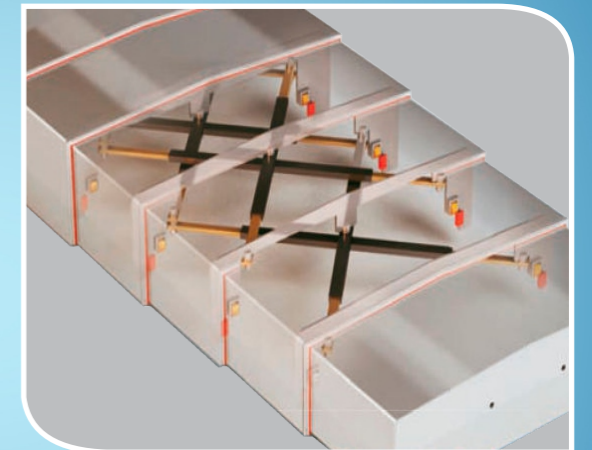
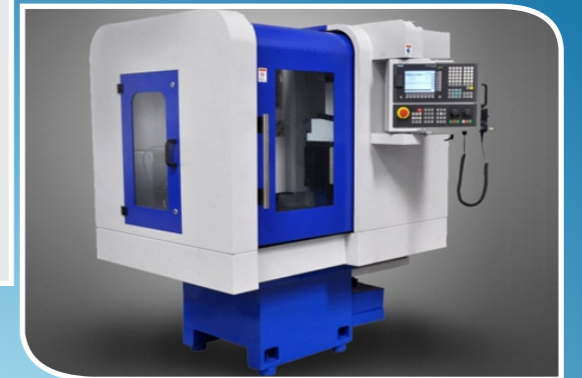

GUJAR INDUSTRIES

(Machine Tools Protection Equipment Division)

Gat No.188 Jyotiba Nagar, Talawade Road,
Talawade Pune – 411062 .
Maharashtra, INDIA
Web: www.gujarindustries.com

Contact No.:
020 32404221, 09960338833 /
09657440677 / 9657784266
Email: gujarindustries@gmail.com

COMPANY PROFILE

Started operating in 2007, GUJAR INDUSTRIES is a leading manufacturer and supplier of Bellows Covers, Telescopic Covers, Roll way Covers, Apron Covers and Way Wipers, Scraper conveyors, Machine Claddings / Guards / Enclosures / Coolant Tank quality sheet metal parts. Renowned for manufacturing and supplying above mentioned products, we are also capable enough to deliver the finest engineering solutions for Machining Centers, Heavy Duty Equipments and CNC Machines.

The complete range of products is developed using top quality raw materials, source from reputed manufactures and suppliers available products at very cost effective rates, suitable to customers' budget affordability. Through our unrelenting efforts to offer ultimate satisfaction to our customers, we have attained a position of high repute in the industry.



Impeccable Quality

Bearing in mind the paramount importance of superb high performance of product, many quality parameters of national as well as international standards are followed according to customers' specific requirements. Right from the procurement of raw material to the delivery of fine finished products, a team of QC (Quality Check) Experts monitor the quality of these products. Also, they are passed through various physical tests to examine and enhance the durability and their performance.

Our Facilities

We are engaged in offering, Laser Cutting, CNC Bending, Co2 Welding, Spot Welding, Drilling, Buffing, Polishing Services as per the requirements of our clients. Various machines are used for the cutting of metals. Our machine has the latest technology for metal cutting and fabrication with improved features. We have two CNC Bending Machines in compliance with dimensional specifications and designs as per the requirements of the clients. Furthermore, we assure the quality, accuracy and low maintenance requirement of our services.

Guide way wiper

Way wipers are essential to keep the guideways in a proper functional state, and thus to keep the machine tool permanently in operation.

- ▲ Temperature range -40 °C to 100 °C
- ▲ Support material: Aluminium
- ▲ Wiper lip material: Polyurethane
- ▲ Largely resistant to oils, greases, alkalis and water
- ▲ Pretension approx. 2 mm
- ▲ Replaceable wiper lip
- ▲ Standard length of bar material: 1000 mm



Dimensions and Types

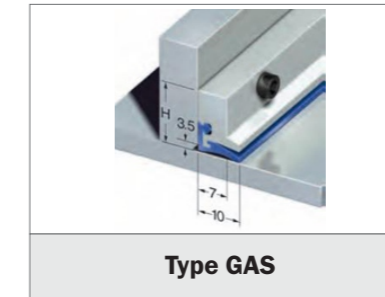
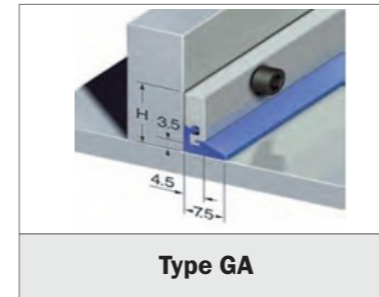

Machine Pendants / Console Boxes

Various types of boxes or Pendants suitable for mounting or accommodating CNC controllers, key boards, mouse pads, Machine control Panels (MCP), Push Button (PB) Switches, Air-conditioned/Fan/Filter, Various ports and switches are required to be provided on machines.

Many a time, operator pendant boxes need to be mounted on the machine guard at a location convenient to the machine operator. In some of the designs, these pendants are provided with swiveling arrangement, so as to swivel or rotate the pendant in the desired direction.

A proper design of these parts considering strength requirement, smoothness in operation, aesthetics and ergonomic factors is very essential.

We duly provide our design and manufacturing services for such items.



Bellow Cover

GUJAR INDUSTRIES bellows are used on all kinds of machine to provide protection for guideway sand spindles, in those cases where no hot chips are present and accessibility is not a requirement. Bellows can be individually produced from a range of different materials, depending on your specific requirements.

Machine tools come in a wide variety of designs. That is why a modern lathe needs another type of telescopic cover than, for example, a large bed-type milling machine. The following designs provide an overview of typical designs.

Designs



U-bellows design



Box bellows design



U-bellows design with lamellas



POLYGON BELLOW COVERS

Roll-up Cover

GUJAR INDUSTRIES roll-up covers serve to protect contact surfaces and guideways on all kinds of machine.

- ▲ Stable metal plate construction
- ▲ Standardized housing cross-section with variable width
- ▲ Robust worm gear motor with torque switching
- ▲ Customized discharge height
- ▲ Customized incline standards = 30°, 45° and 60°
- ▲ Floor mounting or as a push-in version into the machine base



Apron Cover

GUJAR INDUSTRIES roll-up covers serve to protect contact surfaces and guideways on all kinds of machine.

- ▲ Small space requirement
- ▲ Protection against chips and lubricant
- ▲ Splash- and hose-proof
- ▲ Low weight
- ▲ Long service life
- ▲ Heat-resistant to 100 °C over extended Periods Customized end attachment
- ▲ Lateral guides are not necessary
- ▲ Short delivery time
- ▲ Attractive price/performance ratio



Machine Enclosure / Claddings / Guards

GUJAR INDUSTRIES Machine Enclosures are particularly used in CNC / VMC / HMC / SPM machines, and can be manufactured in accordance to the size specifications detailed for machines. Our enclosures are very effective in protecting machine from all kinds of damage. Moreover, these are available at extremely cost-effective prices.



In the earlier days of mass production and rigid manufacturing processes, considerations like aesthetics, cleanliness, operator safety and machine guards were hardly given any importance beyond a certain statutory level of requirements.

With the advancement in cutting tools, increased cutting speeds and feeds, use of stand-alone, dedicated coolant re-circulation system and use of flood coolant for disposal of chips using conveyers, the 'Machine Guard', 'Machine cladding' or 'Machine Enclosure' started playing an important role in the operation of machines.

With more and more machine tool manufacturers displaying their machines in various machine tools exhibitions; domestic as well as worldwide; a lot of effort is being made by machine manufacturers so as to enhance the aesthetics of the machine, to make it operator-friendly (ergonomically built), to make it competitive in price and compact in size and of course, to make it leak-proof; confining the coolant and chips within the machine system; thus safeguarding the painted floors of the modern machine shops.

The machine designer is always overloaded with issues related to speed, cycle time, vibrations and chatter, Process -Capability (Cp, Cpk), Process -performance (Pp, Ppk), etc. The machine designer always considers the task of designing a machine guard as time-consuming.

The manufacturing process of sheet metal parts is different than that of machining parts. The quantity and customer-specific variations do not justify the use of pressed parts or other Mass Scale production Techniques in the manufacturing of machine guards. This is where THE Machine Guard Designer like GUJAR INDUSTRIES . proves advantageous!



Hinged belt conveyors / Scraper conveyors

GUJAR INDUSTRIES Machine Enclosures are particularly used in large machines, and can be manufactured in accordance to the size specifications detailed for diverse equipment. Our enclosures are very effective in protecting machine parts from all kinds of damage. Moreover, these are available at extremely cost-effective prices.



Structure

- ▲ Stable metal plate construction
- ▲ Standardized housing cross-section with variable width
- ▲ Robust worm gear motor with torque switching
- ▲ Customized discharge height
- ▲ Customized incline standards = 30°, 45° and 60°
- ▲ Floor mounting or as a push-in version into the machine base

Accessory examples

- ▲ Motor monitoring systems with current-monitoring relay
- ▲ Other overload safety devices (on request)
- ▲ Coolant container with pump station
- ▲ Direct electrical connection to your machine controller
- ▲ Other special solutions are available. Please do get in touch with us, we will be happy to advise you. Transportation of the material takes place on the upper trough of a revolving hinged belt. Drivers ensure transport of the material up the inclined section. For wet machining the cooling lubrications are collected in the conveyor housing and can be fed back into the machine circuit via an optionally available coolant container or a pump station.

Our hinged belt / scraper conveyors can be used either as stand-alone conveyors at machine tools, or as linked conveyor systems. Depending on the design, the material to be conveyed is brought to the required height at a defined incline and then discharged.



Telescopic Cover

Telescopic covers are generally produced from cold-rolled uncoated thin plates in thicknesses from 1 to 3 mm. Wherever guideways on machines have to be protected, we have a suitable solution. Our guideway protection systems boast a high degree of operational reliability, a long service life, and make use of innovative technical solutions in vertical & cross rail application.

GUJAR INDUSTRIES Telescopic covers are sturdy, most durable & designed with easily replaceable highly anti wear polyurethane & synthetic rubber wipers, dampers, phosphor bronze / engineering plastic guide shoes

- ▲ Rollers / sliders
- ▲ Lifting element
- ▲ Locking system
- ▲ Synchronising device (harnesses)



Telescopic Covers Wipers



Plastic Sliders



Plastic Rollers



Steel Rollers



Y Axis Telescopic Cover



AMC of Protection Covers for keeping your machines always in good healthy running condition:

In this day of just in time inventories and production unplanned machine failure and its downtime due to the failure of way covers can cause major losses from idle laborers, overtime, missed deadlines and promise dates and lost of sales and profit.

We offer periodic scheduled preventive maintenance Programme for your protection covers like telescopic covers, rollway covers, and apron covers. Bellow covers, way wipers, cable drag chains etc.

Our experienced technician will visit to your works as per schedule. During his visit he will open the cover, clean and lubricate the guide ways and cover he will inspect and replace perishable items like wipers, Guide shoes, rollers, and spring etc refit the cover on your equipment.